

Andover Continuum™ Infinet II

bCX1 Controller/Router Series

The Andover Continuum bCX1 is a feature-rich yet cost-effective network controller that supports the Andover Continuum Infinet family of field controllers.



Andover Continuum Infinet II bCX1 Controller/Router Series Features



PRODUCT AT A GLANCE

- 10/100 Ethernet Port
- Expandable for local I/O and display using xP Expansion Modules
- Advanced Flash Memory provides utmost reliability – stores application program, operating system, and run-time data
- Flash memory allows easy online software updates
- Dial-in communications support
- Support for custom Embedded Web Server
- SNMP Monitoring
- SNMP Alarming option
- Support for 2nd Generation Andover Continuum XDrivers



The controller provides a full function 10/100 Ethernet connection and support for up to 127 Andover Continuum Infinet field controllers with a second communication port available for a modem connection or a Plain English driver. This full function network controller provides global control for all of its field controllers and a simple easy-to-use web configuration interface.

The bCX1 also provides a TCP/IP interface for custom web pages, along with SNMP monitoring and optional SNMP alarm delivery. The bCX1 also has the ability to add expansion I/O for local control via the xP family of expansion modules.

Easy Configuration

The bCX1 is designed with ease-of-installation in mind. All configuration settings are done via a standard web browser — set the IP address and save to Flash. All connections to the bCX1 series controller are accomplished with removable connectors for easy installation, the ability to pre-wire panels, and simple servicing of the unit. LEDs provide simple troubleshooting information and communication activity for all ports.

Dial-in Communication Support

All bCX1 series devices can be accessed via a dial-in modem. CyberStation can be configured to provide a communication connection path to a bCX1, either via a LAN connection or via a dial-in connection.

Andover Continuum Infinet II bCX1 Controller/Router Series Features (continued)

Advanced Flash Memory Management

The bCX1 Series uses non-volatile Flash memory to store the operating system, application programs, and run-time data. When a power loss is sensed, an on-board battery maintains power until setpoints, trends, and other run-time data can be safely transferred to Flash memory. When power is restored, both application and run-time data can be restored. Memory backup or restore settings are configurable. The Flash-based operation system simplifies feature upgrades.

Controller/Router Models

The bCX1 Controller/Router “-CR” models combine a fully programmable controller with an Andover Continuum Infinet router in a single device.

Programmable — The dynamic memory of the bCX1-CR can be allocated for any combination of programs, scheduling, alarming, and data logging using the powerful TAC Plain English programming language. Our object-oriented Plain English, with intuitive keywords, provides an easy method to tailor the controller to meet your exact requirements.

Embedded Web Server — With the power of Plain English, standard HTML web pages can be created and embedded into the bCX1-CR to provide a simple-to-use, browser-based interface for monitoring or changing data points. The embedded web pages are fully customizable to meet any special customer requirements.

Expansion I/O — The bCX1-CR contains an I/O expansion port for the addition of up to two Andover xP expansion modules directly on the bottom of the controller. The xP family of modules includes the xPDI8, xPDO2, xPDO4, xPAO2, xPAO4, xPUI4, xPBD4, and xPBA4. In addition, the I/O bus supports the xP Local Display Module, which allows the user to view and change point values.

Dimensional Drawing

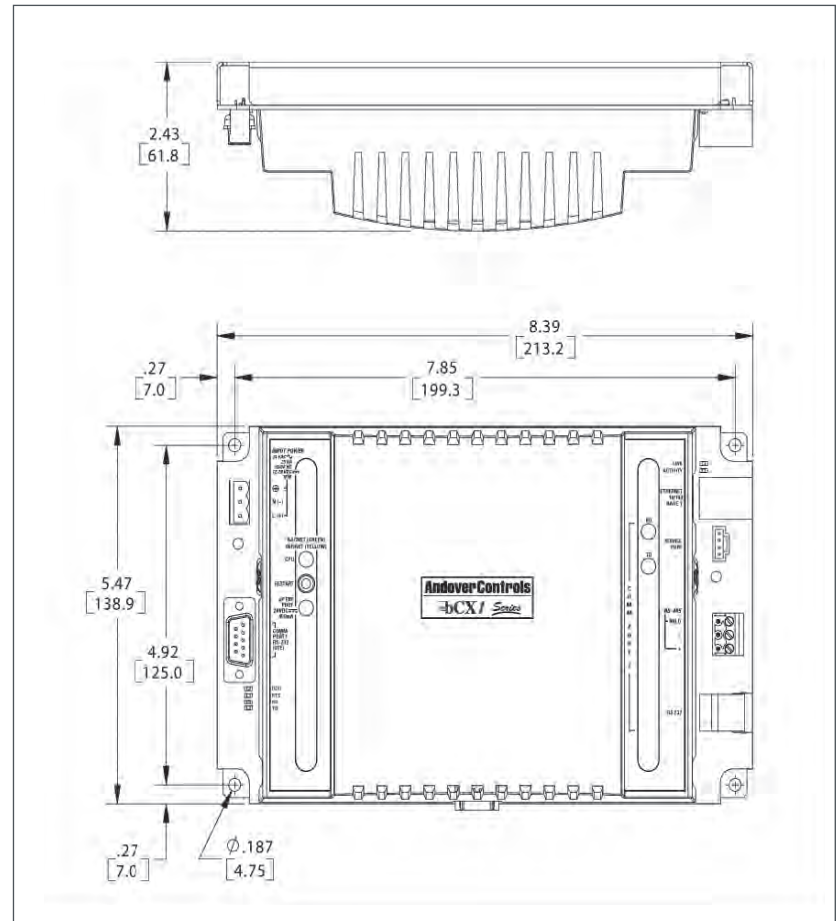

Andover Continuum Infinet II bCX1 Controller/Router Series Features (continued)

SNMP Support — The bCX1-CR is compatible with SNMP monitoring tools, which allows the bCX1 controllers to be interrogated for basic SNMP information. It features advanced SNMP alarm functionality as an option, providing alarm delivery for any device on the Andover Continuum Infinet network it manages.

Wireless Andover Continuum Infinet II Field Bus Support — When using a Wireless Adapter on the service port of a bCX1-CR-INF, it can support a Wireless Andover Continuum Infinet II Field Bus — connecting up to 32 wireless i2 Andover Continuum Infinet controllers per bCX1. Connect into the bCX1 and graphically view the wireless Infinet network using the Wireless Maintenance Tool software.

XDriver Support — The Andover Continuum Infinet bCX1 Controller/Router is available with XDriver Support for 2nd generation Andover Continuum XDrivers to interface with third-party devices. This simplifies system design by allowing direct communications to other protocols and is ideal for a fully integrated building management solution.

Power and Communications

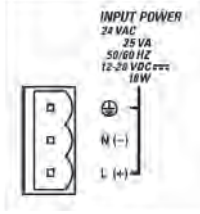

Power Drawing

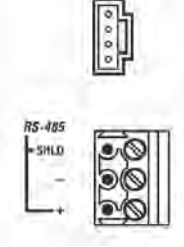

RS-485 Communications Drawing

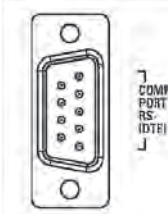

RS-232 Communications Drawing

Andover Continuum Infinet II bCX1 Controller/Router Series Specifications

bCX1 Controller/Router Series

Electrical

Power

24VAC, +10% -15%, 50/60 Hz
12-28 VDC auto-sensing

Power Consumption

40 VA, 25W

Overload Protection

Fused with 3 amp fuse.
MOV protected

Real-Time Clock

Battery-backed real-time clock

Mechanical

Operating Environment

32°–120°F (0–49°C),
10–95% RH (non-condensing)

Size

Module: 5.47" H x 8.39" W x 2.43" D
(139 H x 213 W x 62 D) mm

Weight

Module: 1.12 lb (0.508 kg)

Enclosure Type

UL Open class, IP 20
Flammability rating of UL94-5VB

Mounting

Panel mount

Battery

Battery Backup

Replaceable, rechargeable battery.
Provides 30 days typical accumulated
power failure backup of RAM memory.
All data stored in Flash on power loss.

Communications

TCP/IP

10/100 BaseT*

Communications Interface, Andover Continuum Infinet

RS-485, 127 devices max

Communications Interface, Wireless Infinet

RS-485, 32 devices max

Communications Speed, Infinet

300 - 19.2K baud

RS-485 Bus Length

4,000 ft. (1,220m) standard;
Infilink repeater allows extension
to longer distances.

RS-485 Bus Media

Twisted, shielded pair,
low capacitance cable

*Note: Auto-sensing cable polarity

Connections

Power

3-position removable screw
terminal connector

Communications

Ethernet RJ-45

Comm1: 9-pin D-Sub-female-DTE

Comm2: RS-485 Infinet: Removable

3-position screw terminal
connector

RS-485 Wireless Infinet II:

4-position shrouded
connector (Service Port)

(if RS-485 port is not used):

RJ-45 8-pin (only 3 of the 8
pins are supported

- RXD, TXD, GND)

Expansion Port

6-position shrouded connector

User LEDs/Switches

Status Indicator LEDs

CPU CPU Active
(Yellow = Infinet)

COMM1:

TD-232 Transmit Data-RS-232

RD-232 Receive Data-RS-232

DCD-232 Data Carrier Detect

RTS-232 Request to Send

ETHERNET Link/Act

10/100 Mbps

COMM2:

TD-485 Transmit Data-RS-485

RD-485 Receive Data-RS-485

EXPANSION

PORT PWR Power Status

Switches

CPU RESET

IP ADDRESS RESET

Andover Continuum Infinet II bCX1 Controller/Router Series Specifications (continued)



bCX1 Controller/Router Series

General

Memory

32MB SDRAM, 16MB FLASH

Processor

Motorola 32-bit Coldfire, 66 MHz

Network Setup

Via embedded web interface

Note: bCX1 REQUIRES Andover

Continuum software v1.7 version (or later)

Agency Listings

UL/CUL 916, FCC CFR 47 Part 15,
ICES-003, EN55022, AS/NZS 3548,
Class A, VCCI, EN61000-6-1, CE

Models

Andover Continuum Infinet Controller/Routers

BCX1-CR-0-INF

Controller/Router, 0 Node Support, Infinet

BCX1-CR-8-INF

Controller/Router, 8 Node Support, Infinet

BCX1-CR-32-INF

Controller/Router, 32 Node Support, Infinet

BCX1-CR-64-INF

Controller/Router, 64 Node Support, Infinet

BCX1-CR-127-INF

Controller/Router, 127 Node Support, Infinet

Options

-RA

Redundant Alarming Option

-SA

SNMP Alarming Option

-S

Smoke Control Option

-X1 or -X2

XDriver Enabled for CommPort

1 or 2, respectively

All brand names, trademarks and registered trademarks are the property of their respective owners. Information contained within this document is subject to change without notice.

On October 1st, 2009, TAC became the Buildings Business of its parent company Schneider Electric. This document reflects the visual identity of Schneider Electric, however there remains references to TAC as a corporate brand in the body copy. As each document is updated, the body copy will be changed to reflect appropriate corporate brand changes.

Schneider Electric One High Street, North Andover, MA 01845 USA Telephone: +1 978 975 9600 Fax: +1 978 975 9674 www.schneider-electric.com/buildings

SDS-INFINET-BCX1-A4.BU.N.EN.10.2008.0.00.CC

October 2008 pdw